

seepex.com
all things flow

Here are the base plates and drives
for your pump solution.

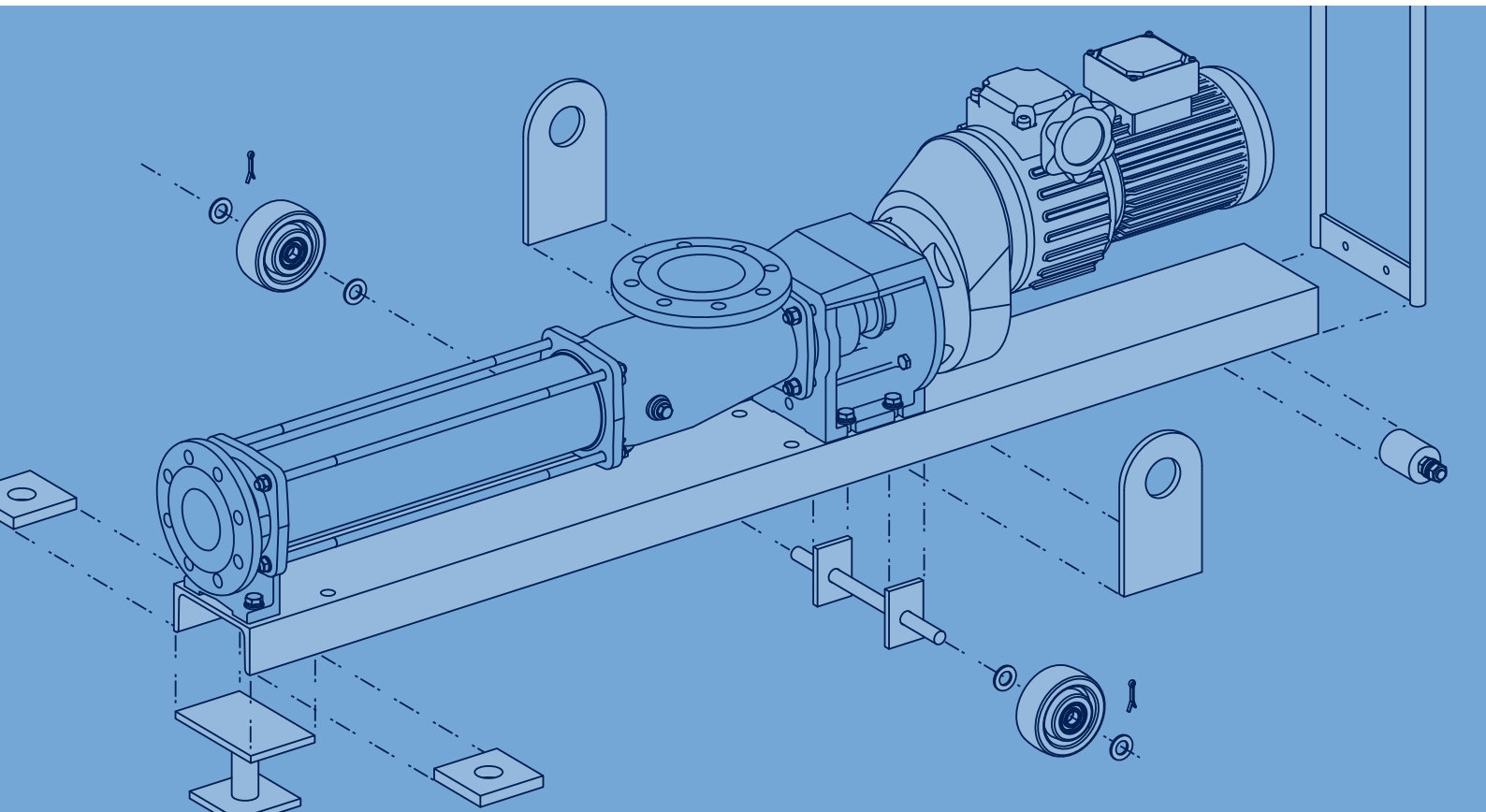

The essentials about the right base plates and drives.

With our pumping solutions, the principle of individuality applies. Each pump is customized to comply with the uniqueness of an industrial sector, a branch, a special business, location and of course the conveying product. On this basis we have developed a modular system consisting of 8 product groups and 27 ranges for which there are also different drives and base plates.

The base plate serves as a connecting element between the pump and the floor. Our progressive cavity pumps are mounted on them and give our pumping technology a secure base. Depending on the requirements and use, they are optimally adapted to the specific pumping process. In addition, an extensive program of accessories is available for increased operational safety and reliability as well as longer service life and optimal product feeding.

The drives ensure an efficient and smooth conveyance of the products. The type of drive and its capacity is also individually adapted to the pump and the duty for each respective application. Our electric motors combine both high performance and energy efficiency, demonstrating the wide range of our pump engineering.

The drive and base plate configurations shown at the beginning of the brochure can be used for most varied industrial applications. What follows are special versions for the requirements of the food industry and the oil and gas industry.

All products shown are available universally but can be supplemented by special constructions, such as hydraulic motors.

The type code in the following tables (in blue) is intended to simplify ordering for you and helps us by facilitating the quick allocation to the individual product groups and ranges and to identify special requirements of the base plate/drive combinations.

The type code is composed of up to three possible positions: the first labels the base plate/drive combination, which has from one to six positions (letters and, if need be, number combinations).

The second position is the designation with two letters each for the materials from painted steel to stainless steel.

The third position stands for further options and accessories, from side feet to motor control – this is again in letters and, if need be, numbers. This, by the way, is available also in combination.

Our tip: simply note the required modules and check these with the help of the type code overview on page 15 – or call your sales representative. He will be glad to assist you with advice and service.

For pumps in block design in different industries.

The base plate/drive combinations shown are used in different industries and are available for the following ranges: BN, BTQ, BT, BTE, BTHE, BTM.

Cross section, base plate B/BV



Geared motor	Disco differential variable geared motor	Variable geared motor	Helical bevel wheel motor
Range BN B	B	B	B
Range BTQ B	B	B	B
Range BT BV	BV	BV	BV
Range BTE BV	BV	BV	BV
Range BTHE BV	BV	BV	BV
Range BTM BV	BV	BV	BV

For pumps with free bare shaft in different industries.

The base plate/drive combinations shown are used in different industries and are available for the following ranges: NS/N TQNS, TNS, TENS.

Cross section, base plate N/N2K/T/T2K



Geared motor and flexible coupling	Disco differential variable geared motor and flexible coupling	Variable geared motor and flexible coupling	Gear, electric motor and two flexible couplings
Range NS/N N	N	N	N2K
Range TQNS N	N	N	N2K
Range TNS T	T	T	T2K
Range TENS T	T	T	T2K

Type code overview on page 15

For pumps with free bare shaft and V-belt drives in different industries.

The base plate/drive combinations shown are used in different industries and are available for the following ranges: NS/N, TQNS, TNS, TENS.

Cross section, base plate NKV/NKZ/TKV _____



Cross section, base plate NK2/NK3/TK2/TK3 _____

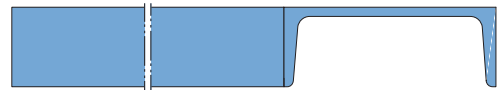

Electric motor and V-belt drive in position "V"	Electric motor and V-belt drive in position "Z"	Geared motor or variable geared motor and V-belt drive in position "2"	Geared motor or variable geared motor and V-belt drive in position "3"
Range NS/N NKV 	Range NS/N NKZ 1) 	Range NS/N NK2 	Range NS/N NK3
Range TQNS NKV 		Range TQNS NK2 	Range TQNS NK3
Range TNS TKV 		Range TNS TK2 	Range TNS TK3
Range TENS TKV 		Range TENS TK2 	Range TENS TK3

1) Only available for product group N in suction branch position 2 or 3

For pumps in block design with bridge breaker in different industries.

The base plate/drive combinations shown are used in different industries and are available for the following range: BTI.

Cross section, base plate BTI2/BTI3

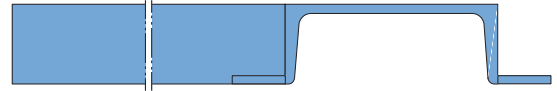

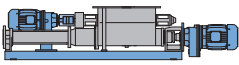
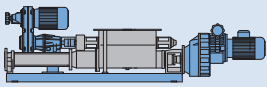
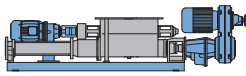
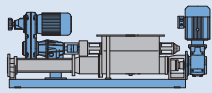
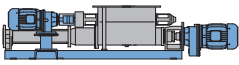
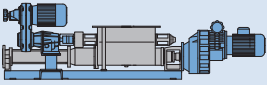
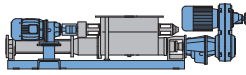
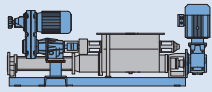
Pump drive: Geared motor Bridge breaker drive: Geared motor	Pump drive: Disco differential variable geared motor Bridge breaker drive: Variable geared motor	Pump drive: Variable geared motor Bridge breaker drive: Geared motor	Pump drive: Helical bevel wheel motor Bridge breaker drive: Variable geared motor
Range BTI	BTI2	BTI2	BTI2
			
Bridge breaker drive:	position 2		
Range BTI	BTI3	BTI3	BTI3
			
Bridge breaker drive:	position 3		

Type code overview on page 15

For pumps in block design with free bare shaft and bridge breaker in different industries.

The base plate/drive combinations shown are used in different industries and are available for the following range: TINS.

Cross section, base plate T12/T13

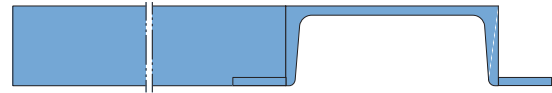

<p>Pump drive: Geared motor and flexible coupling Bridge breaker drive: Geared motor and flexible coupling</p>	<p>Pump drive: Disco differential variable geared motor and flexible coupling Bridge breaker drive: Variable geared motor and flexible coupling</p>	<p>Pump drive: Variable geared motor and flexible coupling Bridge breaker drive: Geared motor and flexible coupling</p>	<p>Pump drive: Variable geared motor and flexible coupling Bridge breaker drive: Variable geared motor and flexible coupling</p>
<p>Range TINS T12</p>	<p>T12</p>	<p>T12</p>	<p>T12</p>
<p>Bridge breaker drive:</p>	<p>position 2</p>		
<p>Range TINS T13</p>	<p>T13</p>	<p>T13</p>	<p>T13</p>
<p>Bridge breaker drive:</p>	<p>position 3</p>		

For pumps in block design with separately driven ribbon auger in different industries.

The base plate/drive combinations shown are used in different industries and are available for the following range: BTH.

Alternatively, this pump can be delivered without separately driven ribbon auger; see BTHE range on page 3 of this brochure.

Cross section, base plate BTH2/BTH3

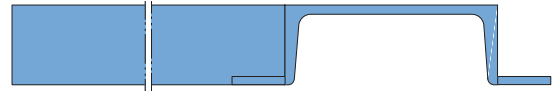

Pump drive:
Geared motor
Ribbon auger drive:
Geared motor

Pump drive:
Variable geared motor
Ribbon auger drive:
Geared motor

Pump drive:
Helical bevel wheel motor
Ribbon auger drive:
Variable geared motor

Range BTH

BTH2

BTH2

BTH2

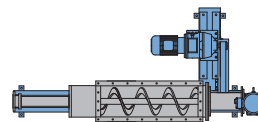
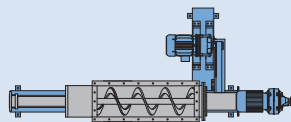
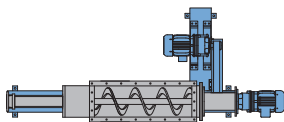

Ribbon auger drive:

position 2

Range BTH

BTH3

BTH3

BTH3

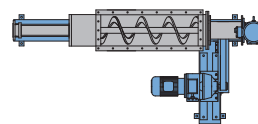
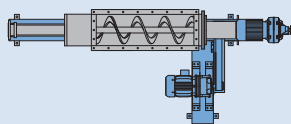
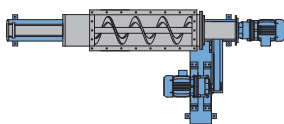

Ribbon auger drive:

position 3

[Type code overview on page 15](#)

For pumps in block design in the food industry.

The base plate/drive combinations shown are used in the food industry and are available for the following ranges: BCSO, BCSB, BTCS.



In order to meet the special needs of the food industry, our hygienic pumps differ from the pumps of the other product groups. The pumps in block design are manufactured in stainless steel, which is the dominant material used in the food industry. You can determine the shape of the base plate from the relevant table and code – from simple (bent sheet: 1) to complicated (frame structure: 7).

Cross section, base plate BES1



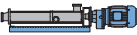
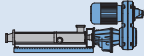
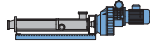

Cross section, base plate BES2/2

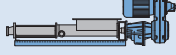
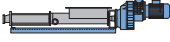

Geared motor	Variable geared motor	Disco differential variable geared motor
Range BCSO/BCSB BES1	BES1	BES1
		
Range BTCS BES1	BES1	BES1
		

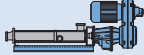
Base plate design: bent sheet

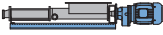
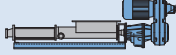
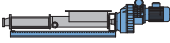
Range BCSO/BCSB BES2/2	BES2/2	BES2/2
		
Range BTCS BES2/2	BES2/2	BES2/2
		

Base plate design: bent sheet with continuous securing straps

[Type code overview on page 15](#)

For pumps in block design in the food industry.

The base plate/drive combinations shown are used in the food industry and are available for the following ranges: BCSO, BCSB, BTCS.

In order to meet the special needs of the food industry, our hygienic pumps differ from the pumps of the other product groups. The pumps in block design are manufactured in stainless steel, which is the dominant material used in the food industry. You can determine the shape of the base plate from the relevant table and code – from simple (bent sheet: 1) to complicated (frame structure: 7).

Cross section, base plate BES3

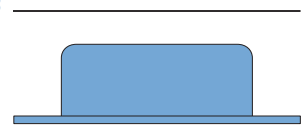

Cross section, base plate BESH4

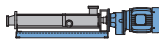
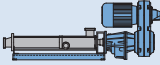
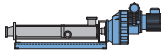
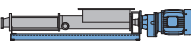
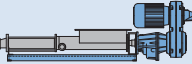
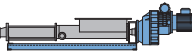

Geared motor	Variable geared motor	Disco differential variable geared motor
Range BCSO/BCSB BES3	BES3	BES3
		
Range BTCS BES3	BES3	BES3
		

Base plate design:

bent sheet with continuous securing straps, closed at frontal side

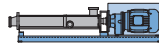
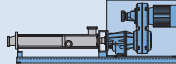
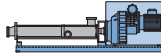
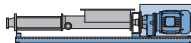
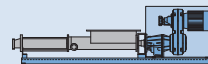
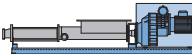
Range BCSO/BCSB BESH4	BESH4	BESH4
		
Range BTCS BESH4	BESH4	BESH4
		

Base plate design:

bent sheet with continuous securing straps, extended version for optional mounting of an drive cover HS

[Type code overview on page 15](#)

For pumps in block design in the food industry.

The base plate/drive combinations shown are used in the food industry and are available for the following ranges: BCSO, BCSB, BTCS.

In order to meet the special needs of the food industry, our hygienic pumps differ from the pumps of the other product groups. The pumps in block design are manufactured in stainless steel, which is the dominant material used in the food industry. You can determine the shape of the base plate from the relevant table and code – from simple (bent sheet: 1) to complicated (frame structure: 7).

Cross section, base plate BESK5

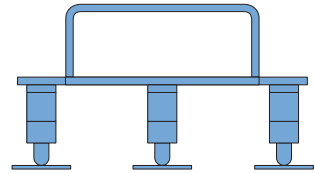

Cross section, base plate BESHK6

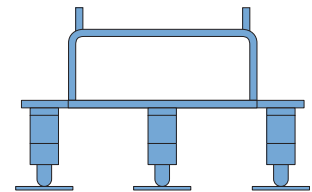

Geared motor	Variable geared motor	Disco differential variable geared motor
Range BCSO/BCSB BESK5	BESK5	BESK5
Range BTCS BESK5	BESK5	BESK5

Base plate design:

bent sheet with calotte feet

Range BCSO/BCSB BESHK6	BESHK6	BESHK6
Range BTCS BESHK6	BESHK6	BESHK6

Base plate design:

bent sheet with calotte feet, extended version for optional mounting of an drive cover HS

Type code overview on page 15

For pumps in block design in the food industry.

The base plate/drive combinations shown are used in the food industry and are available for the following ranges: BCSO, BCSB, BTCS.

In order to meet the special needs of the food industry, our hygienic pumps in block design are manufactured in stainless steel, which is the dominant material used in the food industry. You can determine the shape of the base plate from the relevant table and code – from simple (bent sheet: 1) to complicated (frame structure: 7).

Cross section, base plate BESK7/BESHK7

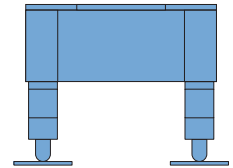

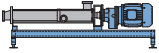
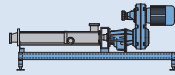
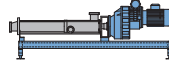
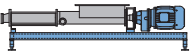
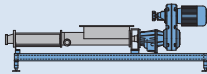
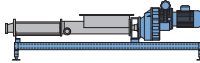
Geared motor	Variable geared motor	Disco differential variable geared motor
Range BCSO/BCSB BESK7	BESK7	BESK7
		
Range BTCS BESK7	BESK7	BESK7
		

Base plate design:

frame structure with calotte feet

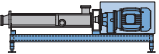
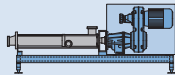
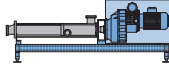
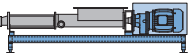
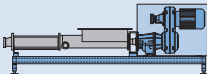
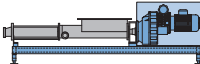
Range BCSO/BCSB BESHK7	BESHK7	BESHK7
		
Range BTCS BESHK7	BESHK7	BESHK7
		

Base plate design:

frame structure with calotte feet, suitable for mounting of a drive cover HS

[Type code overview on page 15](#)

For pumps in block design in the oil and gas industry.

The base plate/drive combinations shown are available for the following ranges: BN, NS, N.

The designation of the base plate is derived from the American standard API 676. "API" stands for "American Petroleum Institute", whose most important area of work is the development of technical guidelines and standards.

An "API" base plate is characterized by, among other things, the following features:

- Lifting lugs
- Leakage drip rim with connection to leakage discharge
- Earthing connections

Cross section, base plate API

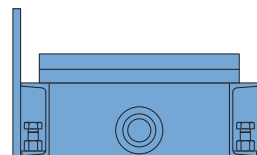

Geared motor

Range BN API

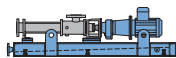

Gear, flexible coupling
and electric motor

Range BN API



Gear, flexible coupling
and electric motor

Range NS/N API

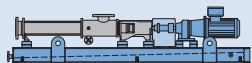

Options and accessories.

The following options and accessories are available for our base plates.

The side feet are used for simple securing of the pump on the foundation.

Side feet LS

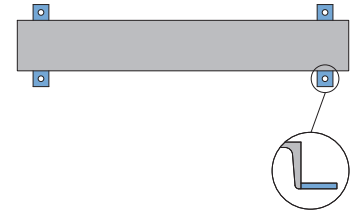

With the help of these lugs, pumps can be transported and installed with a crane at the place where they are to be used. The pump's centre of gravity on the base plate is taken into consideration when the lifting lugs are attached to the base plate.

Lifting lugs TR

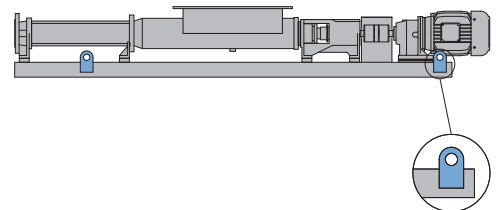

For system-side earthing of the pump.

Earthing connection EA

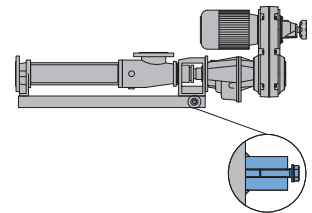

Collecting tray for directed discharge of leakages which may not enter the area of the pump.

Leakage drip rim with connection to leakage discharge LA

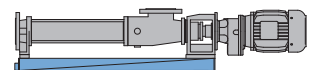

For pumps which are used at several places within the system. Depending on the size of the pump, available as two-wheeled or four-wheeled versions.

Trolley, two-wheeled F2/four-wheeled F4

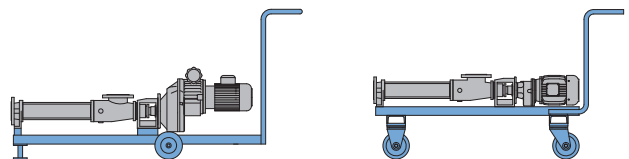

To attach to a pump with trolley. Ready to connect with cable and dry running protection.

Motor control with dry running protection M

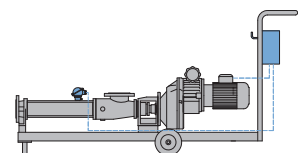

Type code.

The type code of the base plates facilitates the allocation to the individual product groups and ranges and the quick identification of special characteristics of the base plate/drive combinations. The type code is composed of up to three possible positions: the first labels the base plate of the base plate/drive combination. The second position is the designation for the materials. The third position stands for further options and accessories – this, by the way, is available also in combination. An example makes this clear:

B – ST – F4 – M means:

Base plate for ranges BN or BTQ – in steel – with four-wheeled trolley – and motor control.

Base plate/drive combination		Material		Options and accessories	
Position	Range	Position	Configuration	Position	Configuration
B	BN/BTQ	ST	steel, painted	LS	side feet
BV	BT/BTE/BTHE/BTM	ZN	steel, galvanized	TR	lifting lugs
		RI	steel, Rilsan coating	EA	earthing connection
N	NS/N/TQNS	SS	stainless steel	LA	leakage drip rim
N2K	NS/N/TQNS		1.4301, glass bead		with connection to
NKV	NS/N/TQNS		blown		leakage discharge
NKZ	NS/N/TQNS			F2	trolley, two-wheeled
NK2	NS/N/TQNS			F4	trolley, four-wheeled
NK3	NS/N/TQNS			M	motor control
					with dry running protection
T	TNS/TENS				
T2K	TNS/TENS				
TKV	TNS/TENS				
TK2	TNS/TENS				
TK3	TNS/TENS				
BTI2	BTI				
BTI3	BTI				
TI2	TINS				
TI3	TINS				
BTH2	BTH				
BTH3	BTH				
BES1	BCSO/BCSB/BTCS				
BES2/2	BCSO/BCSB/BTCS				
BES3	BCSO/BCSB/BTCS				
BESH4	BCSO/BCSB/BTCS				
BESK5	BCSO/BCSB/BTCS				
BESHK6	BCSO/BCSB/BTCS				
BESHK7	BCSO/BCSB/BTCS				
API	BN/NS/N				

seepex.com
all things flow

And what can we get flowing for you? Your nearest contact:

Or visit www.seepex.com

DRI 6.10E